

Chapter 4: Processes

- Process Concept
- Process Scheduling
- Operations on Processes
- Cooperating Processes
- Interprocess Communication
- Communication in Client-Server Systems

Process Concept

- An operating system executes a variety of programs:
 - ✦ Batch system – jobs
 - ✦ Time-shared systems – user programs or tasks
- Textbook uses the terms *job* and *process* almost interchangeably.
- Process – a program in execution; process execution must progress in sequential fashion.
- A process includes:
 - ✦ program counter
 - ✦ stack
 - ✦ data section

Process State

- As a process executes, it changes *state*
 - ✦ **new**: The process is being created.
 - ✦ **running**: Instructions are being executed.
 - ✦ **waiting**: The process is waiting for some event to occur.
 - ✦ **ready**: The process is waiting to be assigned to a process.
 - ✦ **terminated**: The process has finished execution.

Diagram of Process State

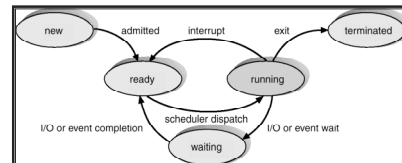

Process Control Block (PCB)

Information associated with each process.

- Process state
- Program counter
- CPU registers
- CPU scheduling information
- Memory-management information
- Accounting information
- I/O status information

Process Control Block (PCB)

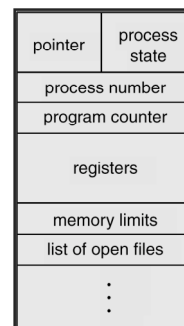

CPU Switch From Process to Process

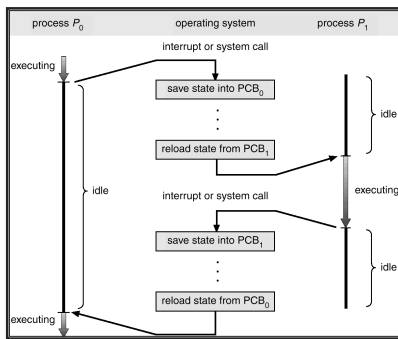

Process Scheduling Queues

- Job queue – set of all processes in the system.
- Ready queue – set of all processes residing in main memory, ready and waiting to execute.
- Device queues – set of processes waiting for an I/O device.
- Process migration between the various queues.

Ready Queue And Various I/O Device Queues

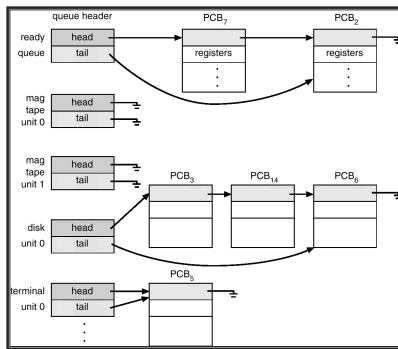

Schedulers

- Long-term scheduler (or job scheduler) – selects which processes should be brought into the ready queue.
- Short-term scheduler (or CPU scheduler) – selects which process should be executed next and allocates CPU.

Schedulers (Cont.)

- Short-term scheduler is invoked very frequently (milliseconds) □ (must be fast).
- Long-term scheduler is invoked very infrequently (seconds, minutes) □ (may be slow).
- The long-term scheduler controls the *degree of multiprogramming*.
- Processes can be described as either:
 - *I/O-bound process* – spends more time doing I/O than computations, many short CPU bursts.
 - *CPU-bound process* – spends more time doing computations; few very long CPU bursts.

Context Switch

- When CPU switches to another process, the system must save the state of the old process and load the saved state for the new process.
- Context-switch time is overhead; the system does no useful work while switching.
- Time dependent on hardware support.

Process Creation

- Parent process create children processes, which, in turn create other processes, forming a tree of processes.
- Resource sharing
 - ✦ Parent and children share all resources.
 - ✦ Children share subset of parent's resources.
 - ✦ Parent and child share no resources.
- Execution
 - ✦ Parent and children execute concurrently.
 - ✦ Parent waits until children terminate.

Process Creation (Cont.)

- Address space
 - ✦ Child duplicate of parent.
 - ✦ Child has a program loaded into it.
- UNIX examples
 - ✦ **fork** system call creates new process
 - ✦ **exec** system call used after a **fork** to replace the process' memory space with a new program.

Processes Tree on a UNIX System

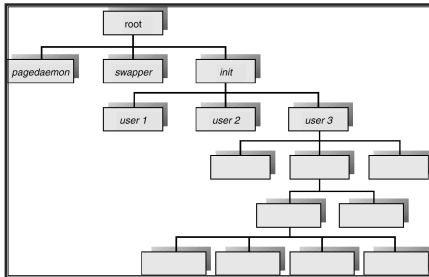

Process Termination

- Process executes last statement and asks the operating system to decide it (**exit**).
 - ✦ Output data from child to parent (via **wait**).
 - ✦ Process' resources are deallocated by operating system.
- Parent may terminate execution of children processes (**abort**).
 - ✦ Child has exceeded allocated resources.
 - ✦ Task assigned to child is no longer required.
 - ✦ Parent is exiting.
 - ✓ Operating system does not allow child to continue if its parent terminates.
 - ✓ Cascading termination.

Cooperating Processes

- *Independent* process cannot affect or be affected by the execution of another process.
- *Cooperating* process can affect or be affected by the execution of another process
- Advantages of process cooperation
 - ✦ Information sharing
 - ✦ Computation speed-up
 - ✦ Modularity
 - ✦ Convenience

Producer-Consumer Problem

- Paradigm for cooperating processes, *producer* process produces information that is consumed by a *consumer* process.
 - ✦ *unbounded-buffer* places no practical limit on the size of the buffer.
 - ✦ *bounded-buffer* assumes that there is a fixed buffer size.

Bounded-Buffer – Shared-Memory Solution

- Shared data

```
#define BUFFER_SIZE 10
typedef struct {
    . . .
} item;
item buffer[BUFFER_SIZE];
int in = 0;
int out = 0;
```
- Solution is correct, but can only use BUFFER_SIZE-1 elements

Bounded-Buffer – Producer Process

```
item nextProduced;

while (1) {
    while (((in + 1) % BUFFER_SIZE) == out)
        ; /* do nothing */
    buffer[in] = nextProduced;
    in = (in + 1) % BUFFER_SIZE;
}
```

Bounded-Buffer – Consumer Process

```
item nextConsumed;

while (1) {
    while (in == out)
        ; /* do nothing */
    nextConsumed = buffer[out];
    out = (out + 1) % BUFFER_SIZE;
}
```

Interprocess Communication (IPC)

- Mechanism for processes to communicate and to synchronize their actions.
- Message system – processes communicate with each other without resorting to shared variables.
- IPC facility provides two operations:
 - + **send**(*message*) – message size fixed or variable
 - + **receive**(*message*)
- If *P* and *Q* wish to communicate, they need to:
 - + establish a *communication link* between them
 - + exchange messages via send/receive
- Implementation of communication link
 - + physical (e.g., shared memory, hardware bus)
 - + logical (e.g., logical properties)

Implementation Questions

- How are links established?
- Can a link be associated with more than two processes?
- How many links can there be between every pair of communicating processes?
- What is the capacity of a link?
- Is the size of a message that the link can accommodate fixed or variable?
- Is a link unidirectional or bi-directional?

Direct Communication

- Processes must name each other explicitly:
 - + **send**(*P, message*) – send a message to process *P*
 - + **receive**(*Q, message*) – receive a message from process *Q*
- Properties of communication link
 - + Links are established automatically.
 - + A link is associated with exactly one pair of communicating processes.
 - + Between each pair there exists exactly one link.
 - + The link may be unidirectional, but is usually bi-directional.

Indirect Communication

- Messages are directed and received from mailboxes (also referred to as ports).
 - ✦ Each mailbox has a unique id.
 - ✦ Processes can communicate only if they share a mailbox.
- Properties of communication link
 - ✦ Link established only if processes share a common mailbox
 - ✦ A link may be associated with many processes.
 - ✦ Each pair of processes may share several communication links.
 - ✦ Link may be unidirectional or bi-directional.

Indirect Communication

- Operations
 - ✦ create a new mailbox
 - ✦ send and receive messages through mailbox
 - ✦ destroy a mailbox
- Primitives are defined as:
 - send**($A, message$) – send a message to mailbox A
 - receive**($A, message$) – receive a message from mailbox A

Indirect Communication

- Mailbox sharing
 - ✦ $P_1, P_2,$ and P_3 share mailbox A .
 - ✦ P_1 sends; P_2 and P_3 receive.
 - ✦ Who gets the message?
- Solutions
 - ✦ Allow a link to be associated with at most two processes.
 - ✦ Allow only one process at a time to execute a receive operation.
 - ✦ Allow the system to select arbitrarily the receiver. Sender is notified who the receiver was.

Synchronization

- Message passing may be either blocking or non-blocking.
- **Blocking** is considered **synchronous**
- **Non-blocking** is considered **asynchronous**
- **send** and **receive** primitives may be either blocking or non-blocking.

Buffering

- Queue of messages attached to the link; implemented in one of three ways.
 1. Zero capacity – 0 messages
Sender must wait for receiver (rendezvous).
 2. Bounded capacity – finite length of n messages
Sender must wait if link full.
 3. Unbounded capacity – infinite length
Sender never waits.

Client-Server Communication

- Sockets
- Remote Procedure Calls
- Remote Method Invocation (Java)

Sockets

- A socket is defined as an *endpoint for communication*.
- Concatenation of IP address and port
- The socket **161.25.19.8:1625** refers to port **1625** on host **161.25.19.8**
- Communication consists between a pair of sockets.

Socket Communication

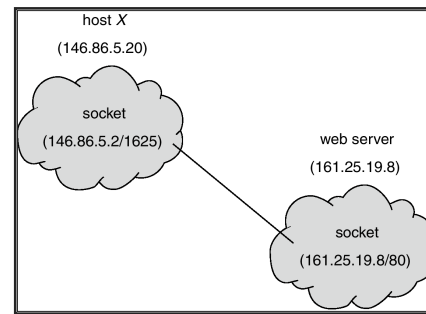

Remote Procedure Calls

- Remote procedure call (RPC) abstracts procedure calls between processes on networked systems.
- **Stubs** – client-side proxy for the actual procedure on the server.
- The client-side stub locates the server and *marshalls* the parameters.
- The server-side stub receives this message, unpacks the marshalled parameters, and performs the procedure on the server.

Remote Method Invocation

- Remote Method Invocation (RMI) is a Java mechanism similar to RPCs.
- RMI allows a Java program on one machine to invoke a method on a remote object.

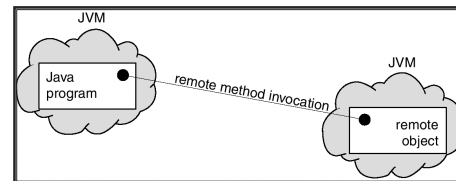

Marshalling Parameters

